

An economic necessity

*Perfect overload protection for
Machine Tools
Packaging Machinery
Automated Systems
Power Transmission Equipment*



NEW
from the
market leader

EAS[®] -smartic[®]

*Torque limiting clutch for a space
optimised installation*

- *Simple direct readability of the torque setting*
- *Easy and quick assembly via a clamping hub*
- *Backlash-free torque transmission*
- *Good dynamic characteristics*

mayr[®]

your reliable partner

www.mayr.de

P.481.V01.GB

EAS[®]-smartic[®]

The new EAS[®]-smartic[®] offers so many advantages that it becomes a necessity for reliable overload protection. Optimum safety and performance for such a small installation space. Do not make compromises, trust in the drive security experience of the market leader!



Characteristics and advantages of the EAS[®]-smartic[®]:

- ❑ **Very easy and quick assembly via single screw clamping hub**
- ❑ **Durable backlash-free torque transmission**
- ❑ **Good dynamic characteristics**
- ❑ **Economic and reliable**
- ❑ **Simple and safe torque setting via graduated scale with direct torque indication**
- ❑ **High transmission security with a radial clamping hub and a keyway as an additional option**

Function

The EAS[®]-smartic[®] Type 481 transmits the torque from the input shaft to the drive element, which is mounted at the ball bearing clutch flange. The EAS[®]-smartic[®] Type 484 connects two shafts and the flexible compensates for any shaft misalignments. Backlash-free torque is transmitted throughout the whole service life of the clutch.

The clutch disengages when the pre-set limiting torque is exceeded. The torque reducing immediately. A fitted mayr[®] limit switch scans the disengaging movement and signals the drive off. After removal of the overload the clutch re-engages automatically.

Re-engagement

After removal of the cause of the overload, the clutch automatically re-engages at the same position of disengagement. Input and output components maintain the same angular position to each other.

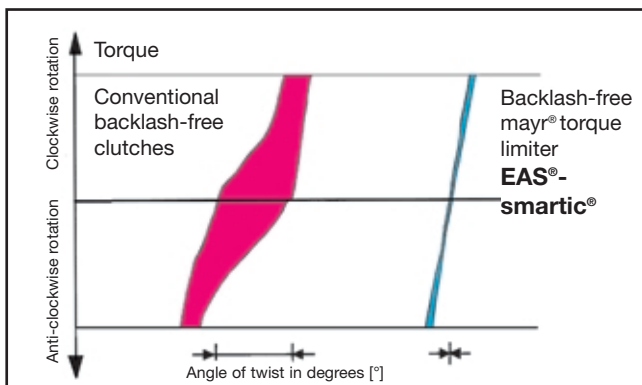

Torque adjustment

No currently available torque limiter offers such easy torque adjustment as the EAS[®]-smartic[®]. If you do not indicate the required torque with your order, we set the clutch to approximately 80 % of maximum torque. The reference marking and torque indication directly indicate the set value.

If you need to re-set the torque to a different value, you must only –

- unscrew the securing screw,
- turn the adjusting nut with a hook wrench until the reference markings point to the required torque,
- slightly correct the adjusting nut until the marking notches are aligned and
- screw in the securing screw.

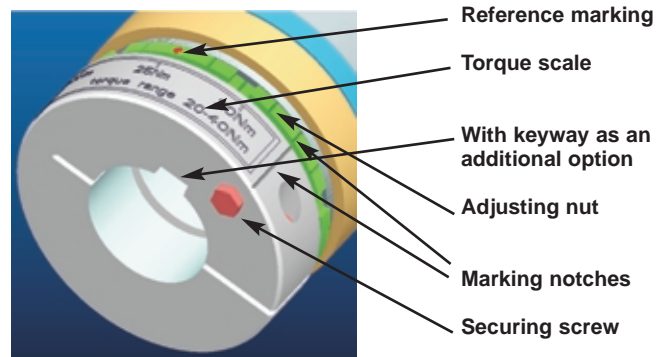

Assembly

Attachment on the shaft – clamping hub

The attachment of the shaft is made by tightening one single screw. The clamping hub is dimensioned to ensure that the maximum torque of the clutch can be transmitted safely and reliably. With an additional keyway as an option for a high transmission security.

Drive elements

The drive elements are located over the ball bearing of the EAS[®]-smartic[®] and attached via screws to the pressure flange.

Backlash of the clutch is:

- the angular tolerance between input and output clutch components
- also known as circumferential backlash
- not to be mistaken with the backlash of the shaft/hub connection
- with mayr[®] backlash-free means:
backlash -> 0
(see graph).

Type chart/application

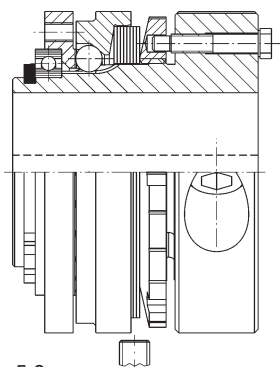

Fig. 1 Type 481_5.0

EAS[®]-smartic[®] flange clutch with clamping hub or clamping hub with keyway for backlash-free torque transmission between shaft and output element.

Technical data and dimensions see page 5.

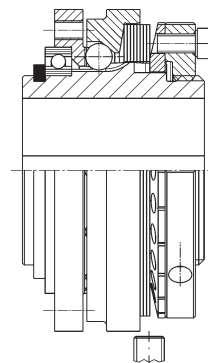

Fig. 3 Type 481_25.0

EAS[®]-smartic[®] flange clutch with keyway hub or backlash-free torque transmission between shaft and input element.

Technical data and dimensions see page 5.

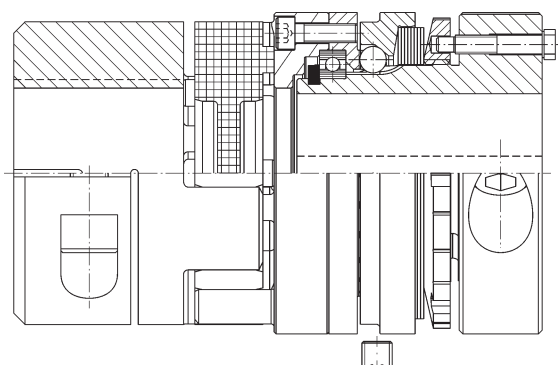

Fig. 2 Type 484_5_

EAS[®]-smartic[®] Lastic backlash-free

Torque limiter with clamping hub or clamping hub with keyway on both sides for backlash-free torque transmission between two coaxial shafts. Compensates axial, radial and angular misalignments. High damping characteristics.

Technical data and dimensions see page 5.

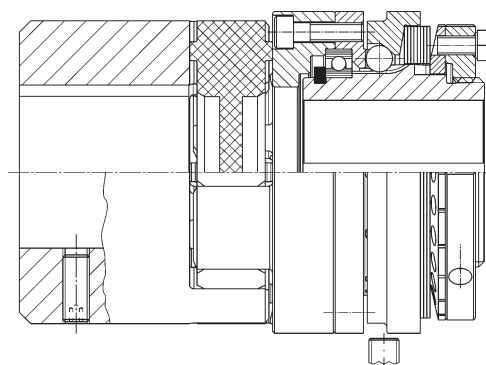

Fig. 4 Type 484_25_

EAS[®]-smartic[®] Lastic backlash-free

Torque limiter with keyway hub on both sides for backlash-free torque transmission between two coaxial shafts. Compensates axial, radial and angular misalignments. High damping characteristics.

Technical data and dimensions see page 5.

Mounting examples

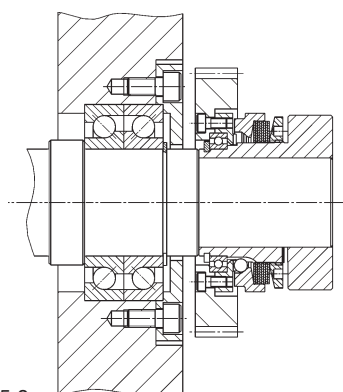

Fig. 5 Type 481_35.0

EAS[®]-smartic[®] flange clutch with clamping hub.

The drive element is centered on the deep groove ball bearing and screwed with the pressure flange. If the resulting radial force is nearly in the middle of the ball bearing, an additional bearing of the input element can be neglected.

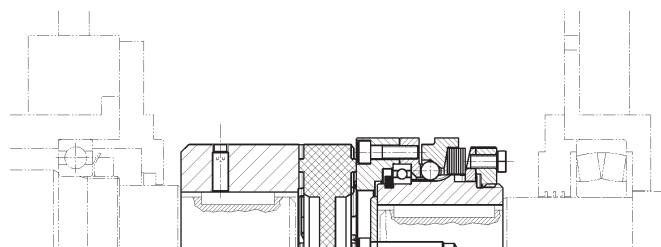

Fig. 6 Type 484_25_

EAS[®]-smartic[®] Lastic backlash-free

Torque limiter with keyway hub on both sides for backlash-free torque transmission between two coaxial shafts.

Compensates axial, radial and angular misalignments. It is axially fixed on the EAS[®]-side via a cover or on the Lastic-side via set screw.

Dimensional drawings

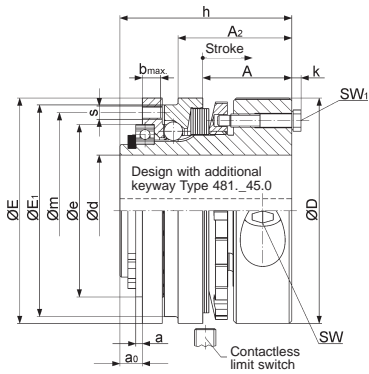

Type 481_35.0

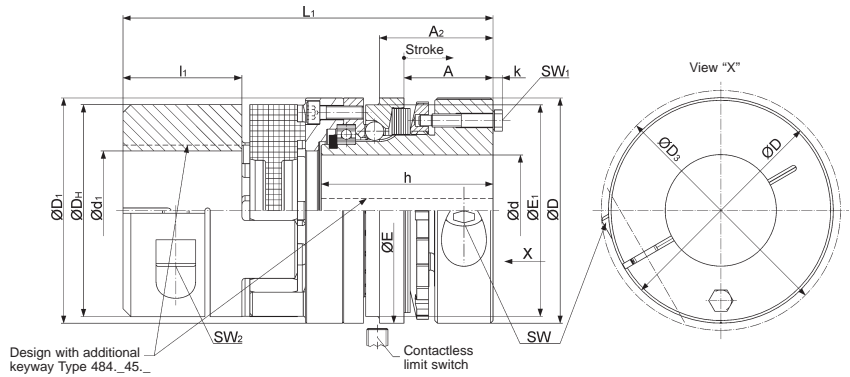

Type 484_35.0

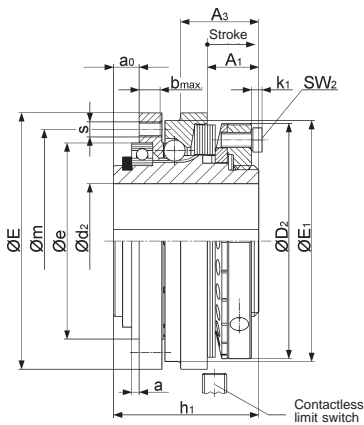

Type 481_25.0

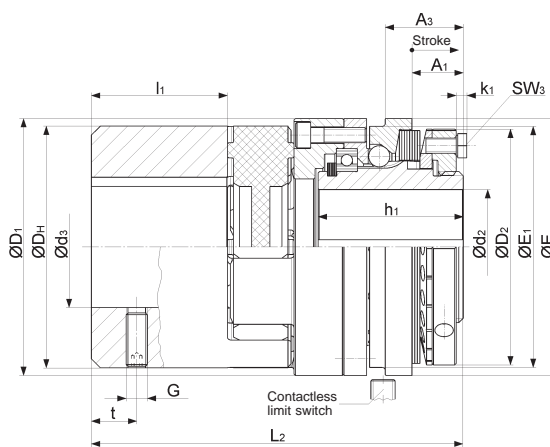

Type 484_25.0

Order example:

To be included when ordering, please state:	Size	Type	Bore Ø d ^{H7}	Bore Ø d ₁ ^{H7}	Bore Ø d ₂ ^{H7}	Bore Ø d ₃ ^{H7}	With limit switch
Order number:		4 8 _ . _ _ 5 . _					see page 6

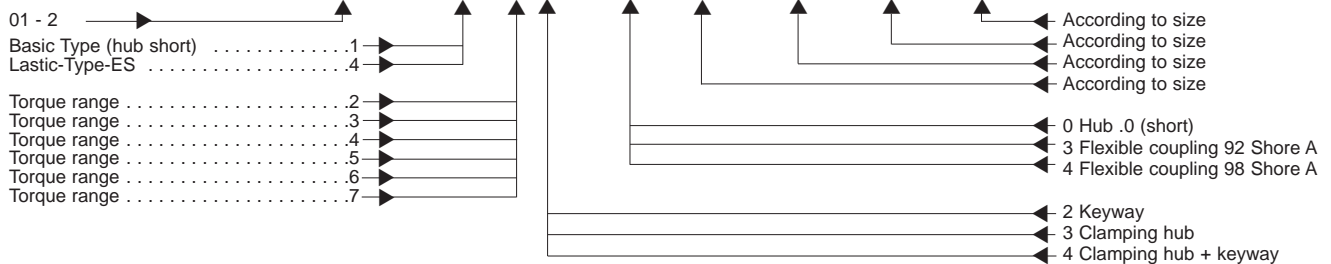

Example: Order number 0 / 481.635.0 / 30 plus limit switch 055.002.5

Accessories (hook wrench for torque setting):

Size	Article number clutch Type 48_25_	Article number clutch Types 48_35_ and 48_45_
01	8170662	8170663
0	4084939	4084158
1	4084939	4084158
2	4084940	4084159

Technical data and dimensions

Size	Limiting torques for overload M_G						Nominal torques flexible, backlash-free shaft coupling $T_{KN}^{1)}$				Max speed n_{max} rpm	Stroke of the thrust washer in the event of an overload mm
	Type						92 Shore A		98 Shore A			
	48_2_5_ Nm	48_3_5_ Nm	48_4_5_ Nm	48_5_5_ Nm	48_6_5_ Nm	48_7_5_ Nm	T_{KN} Nm	$T_{KN max}$ Nm	T_{KN} Nm	$T_{KN max}$ Nm		
01	2,7-5	5-10	8-15	11-20	18-33	32-40	35	70	60	120	3000	0,9
0	5-10	10-20	15-30	20-40	35-65	60-80	95	190	160	320	3000	1,1
1	10-20	20-40	30-60	40-80	70-125	120-160	190	380	325	650	2500	1,3
2	20-40	40-80	60-120	80-160	140-250	240-320	310	620	525	1050	2000	1,5

Size	Tightening torques clamping bolts T_A Nm SW SW ₂		Shaft misalignments flexible coupling					Mass moments of inertia ²⁾			
			axial 92/98 Shore A ΔK_a mm	radial		angular		Input side Clamping hub kgm ²	Output side		
				92 Shore A ΔK_r mm	98 Shore A ΔK_r mm	92 Shore A α °	98 Shore A α °		Type 481 kgm ²	Type 484 kgm ²	
01	40	10	1,4	0,14	0,1	1,0	0,9	0,00017	0,00004	0,00024	
0	40	25	1,5	0,15	0,11	1,0	0,9	0,00056	0,00012	0,00058	
1	81	25	1,8	0,17	0,12	1,0	0,9	0,00151	0,00025	0,00140	
2	140	90	2,1	0,21	0,16	1,0	0,9	0,00320	0,00060	0,00490	

Size	Bores						A	A ₁	A ₂	A ₃	a ³⁾	a ₀	b _{max}	D	D ₁	D ₂	D ₃
	EAS [®] -side			Lastic-side													
	Type 48_25_ $\varnothing d_2^{4)}$	Type 48_35_ $\varnothing d$	Type 48_45_ $\varnothing d^{4)}$	$\varnothing d_1^{1)}$	$\varnothing d_3$												
01	10-22	10-22	10-20	15-28	8-28	29	14	33,5	18,3	2,5	6,5	6	55	57	50	59	
0	14-30	14-32	14-30	19-35	10-38	29	15	37	23	2,5	7,5	6,5	70	70	65	72	
1	19-38	19-42	19-38	20-45	13-45	34	17	43	26	2,5	8,5	7	85	85	78	88	
2	20-45	20-50	20-45	35-55	20-60	38	19	50	31	3,0	9	9,5	100	105	91	104	

Size	D _H	E	E ₁	e _{h5}	G	h	h ₁	k	k ₁	L ₁	L ₂	l ₁	m	s	SW	SW ₁	SW ₂	SW ₃	t
01	55	55	50	42	M5	51	36	2,8	1,5	107	92	30	48	8xM4	6	7	5	5	10
0	65	70	65	52	M6	56	42	2,8	2,8	117	103	35	60	8xM4	6	7	6	7	15
1	80	85	80	65	M8	65	48	3,5	3,5	140	123	45	74	8xM5	8	8	6	8	15
2	105	100	95	78	M8	75	56	4	3,5	170	151	56	89	8xM6	10	10	8	8	25

Size	Preferred bores and friction transmittable torques [Nm] on the diameter d and d ₁ of the hubs with a shaft fit k ₆ Lastic-side and h ₆ /h ₈ EAS [®] -side																		
	$\varnothing 10$	$\varnothing 11$	$\varnothing 12$	$\varnothing 14$	$\varnothing 15$	$\varnothing 20$	$\varnothing 25$	$\varnothing 28$	$\varnothing 32$	$\varnothing 35$	$\varnothing 42$	$\varnothing 45$	$\varnothing 50$	$\varnothing 55$					
	$\varnothing d$	$\varnothing d$	$\varnothing d$	$\varnothing d$	$\varnothing d$	$\varnothing d_1$	$\varnothing d$	$\varnothing d_1$	$\varnothing d$	$\varnothing d_1$	$\varnothing d$	$\varnothing d_1$	$\varnothing d$	$\varnothing d_1$	$\varnothing d$	$\varnothing d_1$			
01	24	27	30	37	40	34	53	54	-	57	-	63	-	-	-	-	-	-	-
0	-	-	-	42	45	-	64	83	80	104	90	116	102	133	-	145	-	-	-
1	-	-	-	-	-	-	88	83	110	104	124	116	142	133	155	145	186	174	-
2	-	-	-	-	-	-	140	-	175	-	210	-	240	-	266	238	320	286	343

1) The transmittable torques of the flexible coupling „T_{KN}“ depend on the factors as for example temperature factor, torsional rigidity factor etc., please contact the factory. Additionally the transmitted torques of the flexible coupling depend on the bore diameter d bzw. d₁.

We reserve the right to make dimensional and design alterations.

2) The mass moments of inertia refer to the couplings with max. bore.

3) Mounting tolerance +0,1

4) Keyway acc. to DIN 6885/3 size 01 with a bore above $\varnothing 17$, size 0 with a bore above $\varnothing 27$, size 1 with a bore above $\varnothing 36$, size 2 with a bore above $\varnothing 43$.

Fitting the limit switch

Set the switch distances for the mechanical or contactless limit switch according to the Fig. shown below.

The distance of the thrust washer from the switching point can sensitively be adjusted with a hexagon head cap screw SW7.

Limit switch (proximity sensing)

Undamped mounting

(The limit switch is damped during disengagement of the clutch.)

Damped mounting

(The limit switch is not damped during disengagement of the clutch.)

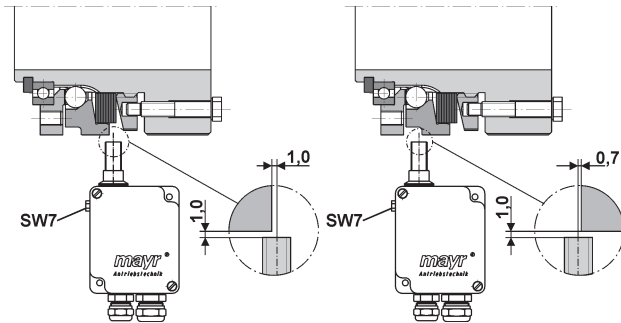

Limit switch Type 055.00_5 (proximity sensing)

Technical data

Input voltage (depending on version)	230 VAC, ±10 %, 50–60 Hz 115 VAC, ±10 %, 50–60 Hz 24 VDC, PELV, ±5 %, reverse polarity protected
Power consumption	max. 1,5 VA
Ambient temperature	-10 °C up to +60 °C limit switch -25 °C up to +60 °C NAMUR-sensor
Protection	IP 54
Conductor cross section	max. 2,5 mm ² / AWG 14
Weight	400 g / 14 oz
Electrical protection	0,1 A/fast acting with 24 VDC (in the supply voltage-line)
Signalling relay	floating toggle contacts contact load max. 250 VAC/12 A contact material AgNi 90/10 max. switching frequency 20 Hz with min. load, 0,1 Hz with max. load
NAMUR-sensor internal	fitted in a light metal enclosure, switching distance SN 2 mm, flush fitting, max. switching frequency 2 KHz, the zero point can be set by 1 mm each by means of the lateral adjusting screw (SW 7).
NAMUR-sensor external	metal enclosure M12 x 1, switching distance SN 2 mm, flush fitting, max. switching frequency 2 KHz, standard cable length 2 m, max. 100 m with a special design, protection IP 67

Order example:

To be included when ordering, please state:	Type	Input voltage
Order number:	055.00_5	___

Proximity sensing		230 VAC
Sensor externally1	→	115 VAC
Sensor internally2	→	24 VDC

Mechanical limit switch

(only possible with size 2)

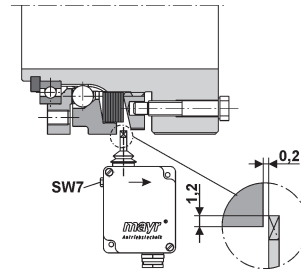

Limit switch Type 055.000.5 (mechanical operation)

Technical data

Micro switch	1 changeover contact 11–12–14
Contact load	Min. 12 VDC/10 mA 250 VAC/15 A 24 VDC/6 A 60 VDC/1,5 A 250 VDC/0,2 A
Contact material	AgCdO 90/10
Switching frequency	max. 200 switching operations/min.
Ambient temperature	-10 °C up to +85 °C
Protection	IP 54
Weight	275 g
Switch travel setting	by the adjusting screw SW 7 arranged laterally the zero shift is possible to right or left by max. 5 mm.
Switch travel	pre-travel: min. 0,5 mm over-travel: max. 10 mm, depending on the zero shift.
Special types	on request different control lever lengths as well as micro switch with 2 changeover contacts.

Order example:

To be included when ordering, please state:	Type
Order number:	055.000.5

Worldwide representation

Headquarters
Chr. Mayr
GmbH + Co. KG
Eichenstraße 1
87665 Mauerstetten
Tel.: 49-83 41/8 04-241
Fax: 49-83 41/804422
info@mayr.de
http://www.mayr.de

Great Britain
Mayr Transmissions Ltd.
Valley Road,
Business Park
Keighley, BD21 4LZ
West Yorkshire
Tel.: 0 15 35/66 39 00
Fax: 0 15 35/66 32 61
sales@mayr.co.uk

Italy
Mayr Italia S.r.l.
Viale Veneto, 3
35020 Saonara (PD)
Tel.: 0 49/8 79 10 20
Fax: 0 49/8 79 10 22
info@mayr-italia.it

France
Mayr France S.A.
Z.A.L. du Minopole
BP 16
62160 Bully-Les-Mines
Tel.: 03.21.72.91.91
Fax: 03.21.29.71.77
contact@mayr.fr

Switzerland
Mayr Kupplungen AG
Tobelackerstrasse 11
8212 Neuhausen
am Rheinfall
Tel.: 0 52/6 74 08 70
Fax: 0 52/6 74 08 75
info@mayr.ch

USA
Mayr Corporation
4 North Street
Waldwick
NJ 07463
Tel.: 2 01/4 45-72 10
Fax: 2 01/4 45-80 19
info@mayrcorp.com

Singapore
Mayr Transmission (S)
Pte. Ltd. – Blk 133
Jurong East Street 13
Unit 03-291
Singapore 600133 Asean
Tel.: 0065/65 60 12 30
Fax: 0065/65 60 10 00
info@mayr.com.sg

China
Mayr Shanghai
Room 608, No. 1277
West Zhongshan Road,
Conch Building,
200051 Shanghai, China
Tel.: 021/62953138
Fax: 021/62953137
sales@mayr.com.cn

Korea
Mayr Korea
60-11, Woongnam-Dong
ROK Changwon
Rep. of Korea
Tel.: 055/262-4024
Fax: 055/262-4025
info@mayrkorea.com

Japan
Sumitomo HI-PTC
Sales Co., Ltd.
3-5-8, Kandakaji-Cho,
Chiyoda-Ku
Tokyo J101-0045
Tel.: 03/52563091
Fax: 03/52563098
Gotou.k@sumiju.co.jp

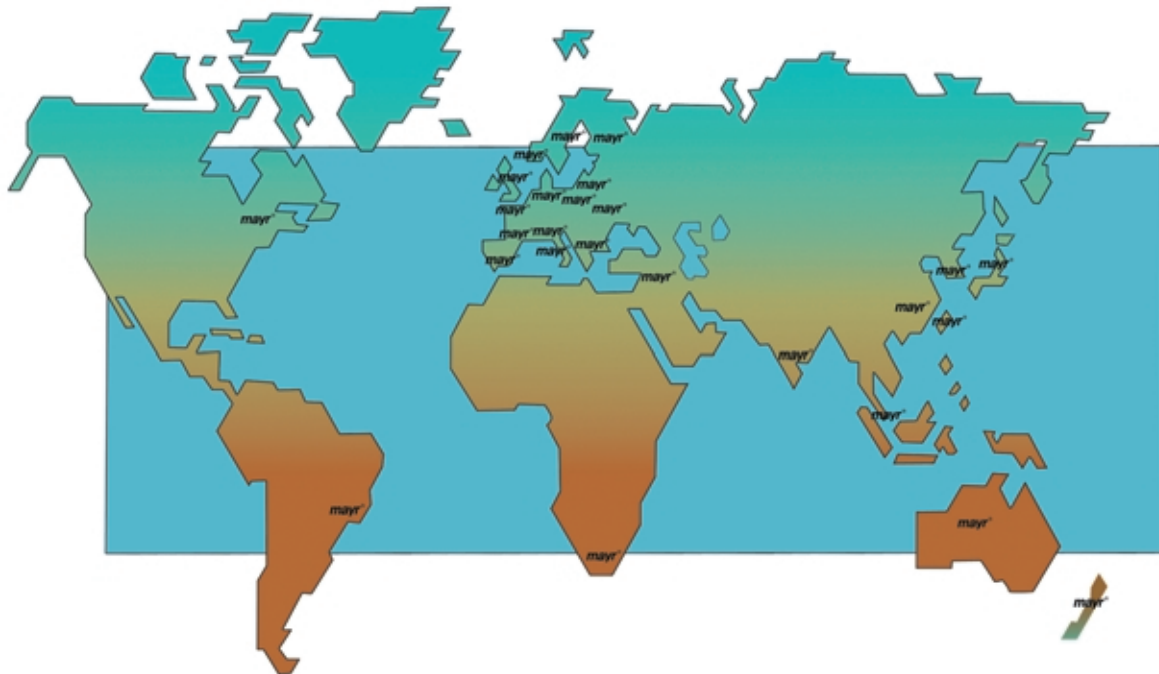

Taiwan
German Tech Auto Co. Ltd.
No. 58, Wu Chuan Road
Wu-Ku Industrial Park
Taipei Hsien, Taiwan
Tel.: 02/22990237
Fax: 02/22990239
steve@zfgta.com.tw

India
National Engineering
Company (NENCO)
J-225, M.I.D.C. Bhosari
Pune 411 026
Tel.: 0202/7474529
Fax: 0202/7470229
nenco@vsnl.com

Australia
Transmission Australia Pty. Ltd.
22 Corporate Ave,
3178 Rowville, Victoria
Australien
Tel.: 039/755 4444
Fax: 039/755 4411
info@transaus.com.au

South Africa
Torque Transfer
Private Bag 9
Elandsfontein 1406
Tel.: 011/3458000
Fax: 011/9740524
torque@bearings.co.za

**Machine Tool
Applications in China**
DTC. Co.Ltd.,
Block 5th, No. 1699,
East Zhulu Road,
201700 Shanghai, China
Tel.: 021/59883978
Fax: 021/59883979
dtschanghai@online.sh.cn

Austria	Hongkong	Poland	Turkey
Benelux States	Hungary	Romania	
Brazil	Indonesia	Russia	
Canada	Israel	Slovakia	
Czech Republic	Malaysia	Slovenia	
Denmark	New Zealand	Spain	
Finland	Norway	Sweden	
Greece	Philippines	Thailand	

Note:
If a country is not shown, please refer to headquarters or our web site to be advised of the nearest responsible agent.

Delivery Programme



Safety clutches/ torque limiters

- ❑ **EAS[®]-Compact[®]/EAS[®]-NC**
Positive, absolutely backlash-free torque limiter
- ❑ **EAS[®]-smartic[®]**
Economic torque limiters with fast assembly
- ❑ **EAS[®]-element clutch/EAS[®]-elements**
Load disconnecting protection for high torques
- ❑ **EAS[®]-axial**
Exact limitation of tensile and compressive forces
- ❑ **EAS[®]-Sp/EAS[®]-Sm/EAS[®]-Zr**
Residual torque free disconnecting torque limiter with ON/OFF function
- ❑ **ROBA[®]-slip hubs**
Load holding, friction type torque limiting clutch
- ❑ **ROBA[®]-contitorque**
Magnetic continuous slip clutch

Shaft couplings

- ❑ **smartflex[®]**
Perfect precision coupling for servo and stepper motors
- ❑ **ROBA[®]-ES**
Backlash-free and damping of vibration critical drives
- ❑ **ROBA[®]-DS/ROBA[®]-D**
Backlash-free, torsionally rigid all-steel coupling
- ❑ **EAS[®]-control-DS**
Low cost torque-measuring coupling

Electromagnetic brakes/clutches

- ❑ **ROBA-stop[®] Standard**
Multi-functionally all-round safety brake
- ❑ **ROBA-stop[®]-M motor brakes**
Robust, cost effective motor brake
- ❑ **ROBA-stop[®]-S**
Waterproof, robust monobloc brake
- ❑ **ROBA-stop[®]-Z/ROBA-stop[®]-silenzio[®]**
Double security elevator brake
- ❑ **ROBA[®]-diskstop[®]**
Compact quiet disk brake
- ❑ **ROBA[®]-topstop[®]**
Brake systems for gravity loaded axes
- ❑ **ROBA[®]-linearstop**
Backlash-free brake system for linear motor axes
- ❑ **ROBATIC[®]/ROBA[®]-quick/ROBA[®]-takt**
Energise to engage electromagnetic pole face clutches and brakes, CBU

DC drives

- ❑ **tendo[®]-PM**
Permanent-magnet D.C. motors
- ❑ **tendo[®]-SC**
1 and 4 Q transistor controllers



Chr. Mayr GmbH + Co. KG
Eichenstrasse 1
D-87665 Mauerstetten
Germany

Telephon 083 41/804-2 41
Telefax 083 41/804 422
<http://www.mayr.de>
eMail: info@mayr.de

mayr[®]
your reliable partner